

Southern Comfort Coil LLC
Second Ave N.E.
Suite 308
St. Petersburg, Florida 33701

REQUEST A QUOTE SAVE \$\$\$\$

Phone: 888-568-4288 Ext 1 Rex Sparks
Rex@southerncomfortcoil.com
www.heatcraftcoil.com

Air Cooled Condensers

800mm
Round Tube Coils

LUVATA
Partnerships beyond metals

800MM

Table of Contents

Nomenclature	2
Overview	3
Features & Options.....	4-5
LCS8 Specifications (1100 RPM).....	6-7
LCU8 Specifications (500 RPM)	8-9
LCV8 Specifications (VSEC)	10-11
Dimensions	12-13
Refrigerant Charge	14
Control Panels & Fan Cycling	15-17
Wiring Diagrams.....	18-19
Condenser Selection Procedure	20-22

Nomenclature

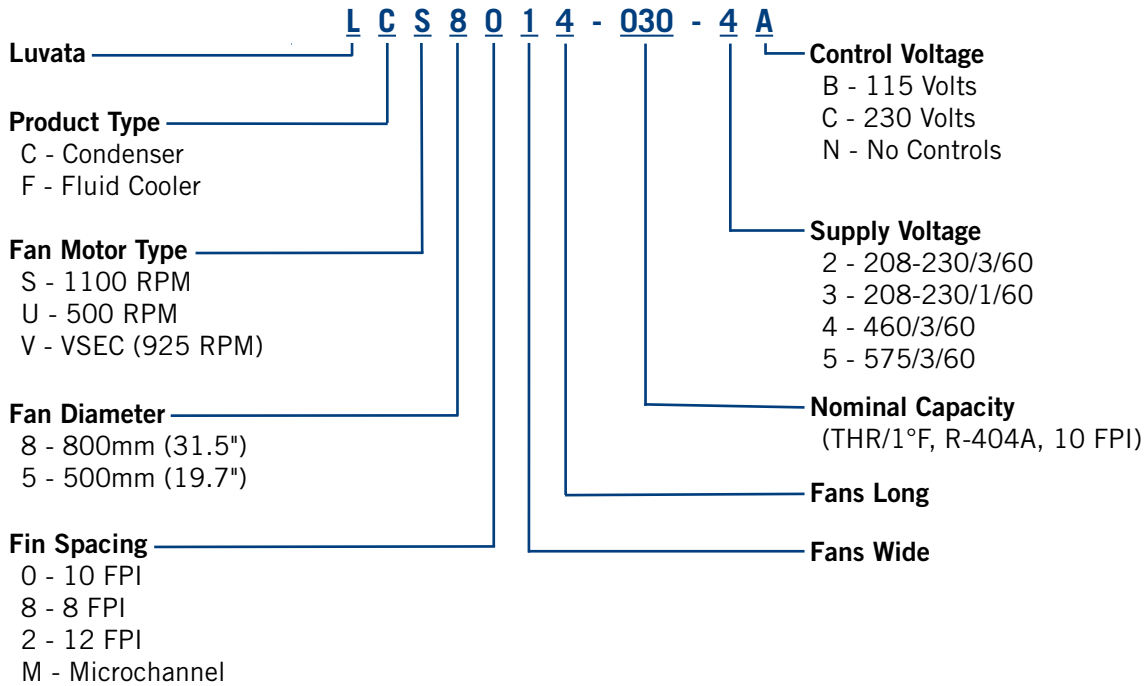

All specifications subject to change without notice.

800MM



No Compromise

At Luvata, we are not very good at compromise – not when it comes to product performance and quality anyway. With over 25 years experience designing, producing, and enhancing air-cooled condensers, we have learned that compromise is not needed to exceed market expectations. Rather, we have selected the highest quality, most technologically advanced materials and combined them with our expertise in engineering and manufacturing to produce startling performance results with unsurpassed quality and reliability.

Typical Performance Results (per 800mm diameter fan motor)

	LCS8 Models (1100 rpm)	LCU8 Models (500 rpm)	LCV8 Models (VSEC*)
Energy Consumption (watts)	1447	391	1495
Sound Pressure Level (dBA @ 3m)	62.5	43.5	58.5

*Variable speed EC motors at full speed (925rpm)

Luvata 800mm Series air-cooled condensers are available in single wide configuration from 1 to 7 fans (11 to 134 Tons) and double wide configuration from 4 to 14 fans (32 to 260 Tons). All are optimized for application with modern, environmentally friendly refrigerants R-404A, R-507, R-410A, and R-134a. Each configuration is available with single speed 1100 rpm or 500 rpm fan motors or with variable speed electronically commutated (EC) fan motors. Our standard features are impressive and our available options are extensive. Take a look at how Luvata will make you unwilling to compromise also.

About Luvata

Luvata is a world leader in metal fabrication, component manufacturing and related engineering and design services. We are committed to partnering with our customers to help them increase their competitiveness. Our products and services enable our customers to improve operational efficiency, improve products and reduce tied-up capital. Because we focus on our customers' results and are unfailingly reliable, we are the partner on which our customers base their future development.

We make every effort to develop and produce the finest and most complete line of air-cooled condensers available. Yet, we recognize that specific customer requirements are often more important than our published specifications. At Luvata, we have a long tradition of meeting these unique needs with outstanding engineering support and flexible manufacturing processes. There is no need to compromise, simply give us a call and see how we can develop a solution that better meets your needs.

No Compromise Standard Features

Large, weather proof electrical enclosure is amply sized to fit even the most advanced controls. Standard equipment includes a main disconnect switch with door interlock and a main terminal block for motor lead termination. Standard control panels are rated at 10 kA SCCR.

Direct drive external rotor motors offer uncompromised energy efficiency, low sound, and the longest trouble free life available.

Single speed 3 phase fan motors are dual voltage and can be easily changed between 208-230V and 460V in the field.

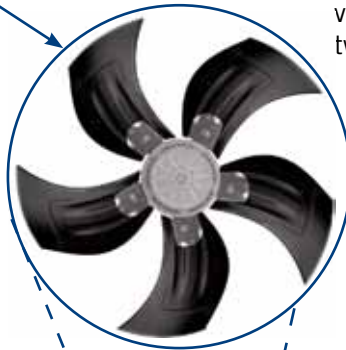

Swept fan blades are designed as part of the motor, not an addition to it. Precise matching of these two components increases energy efficiency and reduces sound pressure to unheard of levels.

Tall venturi fan panels add to our uncompromised energy efficiency and ultra-low sound.

Fully enclosed motor lead raceways to protect wiring.

Pre-painted galvanized steel cabinet provides years of durable finish protection and ascetics.

Fully baffled fan cells prevent "wind milling" and enhance performance.

Round Tube Coils-Enhanced tubing, advanced sinusoidal fin design for optimal performance. Extensive use of 5/16" and 3/8" diameter tubing keeps refrigerant charge to a minimum. Microchannel is more compact than round tube coils and tremendously reduces refrigerant charge.



US Conforms to UL Std. 1995

Intertek
4002117

Certified to CAN/CSA Std. C22.2 No. 236-05

No Compromise Available Options

- Ambient or Pressure fan cycling control. Our preferred controller is the Johnson Controls System 450 for uncompromised performance, reliability and precision. Easily programmed, the System 450 is also used to control our variable speed EC fan motors
- Variable speed EC header fans are available on models LCS8 and LCU8 to fill in the airflow gaps created by on/off fan cycling. Variable speed is controlled by pressure only and may be used in conjunction with pressure or ambient on/off fan cycling
- Variable speed control for LCV8 models to maximize performance
- Microprocessor interface boards to communicate with your rack controller or building management system.
- Condenser splitting controls
- 230VAC or 115VAC control circuit includes branch fusing and transformer (as required)
- Main power supply fusing
- Multi-circuiting of coils at no additional charge
- Condenser flooding valves
- 8 or 12 fins per inch spacing (round tube models)
- ElectroFin E-Coat coil protection
- Extended mounting legs for increased ground clearance

No Compromise Protection

Many features have been built into the Luvata 800mm Series air-cooled condensers to protect your investment – pre-painted galvanized cabinet, high reliability motors, special design coil mounting – to name a few. But what about the coil? Aluminum fins exposed to corrosive environments will pre-maturely deteriorate resulting in performance loss and eventual failure. Ocean salt spray, acid rain, and aggressive contaminants from nearby incinerators, power plants, and industrial smoke stacks all contribute to this process. For these situations, Luvata recommends and offers only the finest coil protection available: ElectroFin E-Coat.

ElectroFin E-Coat provides a uniform, flexible coating over the entire coil with immeasurable impact on thermal conductivity. 100% coverage is assured by the application process, even in the hard to reach center portions of the coil, without bridging between the fins.

Luvata offers ElectroFin E-Coat at an affordable price and with minimum impact on lead times. We recommend the application anytime an air-cooled condenser is located near a salt water coast or a potential source of corrosive airborne particles.



800MM

LCS8 Performance Data

1100 RPM, 1.5 HP, 800mm Fan Diameter								
	Model	Fan Arrangement	Total Heat of Rejection (MBH/1°F TD)			Air Flow (CFM)	Sound Pressure (dBA @ 3m)	Maximum Number of Circuits
			R-404A/R-507	R-410A	R-134a			
Single Wide Models	LCS8011-007	1X1	7.1	7.3	6.5	11,620	62.5	14
	LCS8011-009	1X1	8.9	9.1	8.2	11,270	62.5	18
	LCS8012-011	1X2	11.2	11.5	10.0	24,000	65.5	20
	LCS8012-015	1X2	14.5	14.9	13.2	23,240	65.5	28
	LCS8012-018	1X2	17.3	17.8	15.8	22,540	65.5	34
	LCS8013-022	1X3	21.7	22.4	19.0	34,390	67.3	28
	LCS8013-026	1X3	25.9	26.6	23.0	33,220	67.3	34
	LCS8014-030	1X4	30.0	30.9	26.3	45,860	68.5	38
	LCS8014-035	1X4	35.1	36.3	31.1	44,300	68.5	42
	LCS8015-040	1X5	40.2	41.5	35.6	54,480	69.5	28
	LCS8015-046	1X5	45.8	47.0	41.1	52,060	69.5	36
	LCS8016-054	1X6	54.1	55.5	48.3	62,430	70.3	44
	LCS8017-062	1X7	62.4	64.2	55.5	72,880	71.0	52
Double Wide Models	LCS8022-022	2X2	21.7	22.3	19.5	47,090	68.5	20
	LCS8022-029	2X2	29.0	29.8	26.4	45,270	68.5	28
	LCS8022-035	2X2	34.6	35.5	31.6	43,630	68.5	32
	LCS8023-044	2X3	44.1	45.7	38.2	68,050	70.3	52
	LCS8023-052	2X3	52.4	54.0	46.2	65,580	70.3	68
	LCS8024-060	2X4	60.2	62.3	52.4	90,730	71.5	76
	LCS8024-070	2X4	70.6	72.9	62.3	87,440	71.5	96
	LCS8025-081	2X5	80.9	83.6	70.3	107,320	72.5	64
	LCS8025-091	2X5	91.4	94.0	80.0	102,250	72.5	90
	LCS8026-107	2X6	106.8	110.8	92.4	122,700	73.3	100
	LCS8027-123	2X7	123.3	128.3	106.9	143,150	74.0	140

For 8 FPI Models, multiply MBH by 0.900, CFM by 1.017, and watts by 0.985.

For 12 FPI Models, multiply MBH by 1.074, CFM by 0.979, and watts by 1.016.

800MM



LCS8 Electrical Data

1100 RPM, 1.5 HP, 800mm Fan Diameter									
	Model	208-230/3/60			460/3/60			SCCR	Total Watts
		FLA	MCA	MOPD	FLA	MCA	MOPD		
Single Wide Models	LCS8011-007	6.8	10.0	16	3.6	5.0	9	10kA	1,336
	LCS8011-009	6.8	10.0	16	3.6	5.0	9	10kA	1,407
	LCS8012-011	13.6	16.8	23	7.2	9.0	13	10kA	2,674
	LCS8012-015	13.6	16.8	23	7.2	9.0	13	10kA	2,776
	LCS8012-018	13.6	16.8	23	7.2	9.0	13	10kA	2,870
	LCS8013-022	20.4	23.6	30	10.8	13.0	17	10kA	4,152
	LCS8013-026	20.4	23.6	30	10.8	13.0	17	10kA	4,290
	LCS8014-030	27.2	30.4	37	14.4	16.0	20	10kA	5,536
	LCS8014-035	27.2	30.4	37	14.4	16.0	20	10kA	5,720
	LCS8015-040	34.0	37.2	44	18.0	20.0	24	10kA	7,255
	LCS8015-046	34.0	37.2	44	18.0	20.0	24	10kA	7,540
	LCS8016-054	40.8	44.0	50	21.6	23.0	27	10kA	9,048
LCS8017-062	47.6	50.8	57	25.2	27.0	31	10kA	10,556	
Double Wide Models	LCS8022-022	27.2	30.4	37	14.4	16.0	20	10kA	5,392
	LCS8022-029	27.2	30.4	37	14.4	16.0	20	10kA	5,604
	LCS8022-035	27.2	30.4	37	14.4	16.0	20	10kA	5,796
	LCS8023-044	40.8	44.0	50	21.6	23.0	27	10kA	8,394
	LCS8023-052	40.8	44.0	50	21.6	23.0	27	10kA	8,682
	LCS8024-060	54.4	58.6	65	28.8	31.0	35	10kA	11,192
	LCS8024-070	54.4	58.6	65	28.8	31.0	35	10kA	11,576
	LCS8025-081	68.0	72.2	79	36.0	38.0	42	10kA	14,700
	LCS8025-091	68.0	72.2	79	36.0	38.0	42	10kA	15,300
	LCS8026-107	81.6	85.8	92	43.2	45.0	49	10kA	18,360
	LCS8027-123	95.2	99.4	106	50.4	53.0	57	10kA	21,420

800MM

LCU8 Performance Data

500 RPM, 0.5 HP, 800mm Fan Diameter								
	Model	Fan Arrangement	Total Heat of Rejection (MBH/1°F TD)			Air Flow (CFM)	Sound Pressure (dBA @ 3m)	Maximum Number of Circuits
			R-404A/R-507	R-410A	R-134a			
Single Wide Models	LCU8011-005	1X1	5.1	5.2	4.8	6,858	43.5	14
	LCU8011-006	1X1	6.0	6.1	5.7	6,507	43.5	18
	LCU8012-008	1X2	7.9	8.0	7.4	14,306	46.5	20
	LCU8012-010	1X2	10.2	10.3	9.7	13,422	46.5	28
	LCU8012-012	1X2	11.6	11.7	11.1	12,661	46.5	34
	LCU8013-016	1X3	15.7	15.9	14.4	20,033	48.3	28
	LCU8013-018	1X3	18.0	18.2	16.8	18,828	48.3	34
	LCU8014-021	1X4	20.9	21.2	19.2	26,711	49.5	38
	LCU8014-023	1X4	23.4	23.7	21.7	25,104	49.5	42
	LCU8015-027	1X5	26.9	27.2	24.5	30,737	50.5	28
	LCU8015-030	1X5	30.4	30.6	28.2	28,418	50.5	36
	LCU8016-036	1X6	35.9	36.1	33.3	34,101	51.3	44
	LCU8017-042	1X7	41.6	41.9	38.6	39,789	52.0	52
Double Wide Models	LCU8022-015	2X2	15.4	15.7	14.5	28,127	49.5	20
	LCU8022-020	2X2	20.1	20.4	19.1	36,304	49.5	28
	LCU8022-023	2X2	23.1	23.3	22.0	24,664	49.5	32
	LCU8023-031	2X3	30.6	31.2	27.9	39,353	51.3	52
	LCU8023-036	2X3	35.8	36.2	33.3	36,773	51.3	68
	LCU8024-041	2X4	41.4	42.1	37.9	52,471	52.5	76
	LCU8024-048	2X4	47.8	48.4	44.5	49,030	52.5	96
	LCU8025-053	2X5	53.2	53.9	48.3	59,966	53.5	64
	LCU8025-059	2X5	59.1	59.6	55.0	55,416	53.5	90
	LCU8026-069	2X6	68.8	69.6	63.5	66,253	54.3	100
	LCU8027-082	2X7	81.9	83.0	75.9	77,583	55.0	140

For 8 FPI Models, multiply MBH by 0.923, CFM by 1.037, and watts by 0.987.
 For 12 FPI Models, multiply MBH by 1.077, CFM by 0.961, and watts by 1.015.

800MM



LCU8 Electrical Data

500 RPM, 0.5 HP, 800mm Fan Diameter									
	Model	208-230/3/60			460/3/60			SCCR	Total Watts
		FLA	MCA	MOPD	FLA	MCA	MOPD		
Single Wide Models	LCU8011-005	2.1	4.0	6	1.2	2.0	3	10kA	381
	LCU8011-006	2.1	4.0	6	1.2	2.0	3	10kA	385
	LCU8012-008	4.2	6.1	9	2.4	4.0	5	10kA	756
	LCU8012-010	4.2	6.1	9	2.4	4.0	5	10kA	766
	LCU8012-012	4.2	6.1	9	2.4	4.0	5	10kA	776
	LCU8013-016	6.3	8.2	11	3.6	5.0	6	10kA	1,149
	LCU8013-018	6.3	8.2	11	3.6	5.0	6	10kA	1,167
	LCU8014-021	8.4	10.3	13	4.8	6.0	7	10kA	1,532
	LCU8014-023	8.4	10.3	13	4.8	6.0	7	10kA	1,556
	LCU8015-027	10.5	12.4	15	6.0	7.0	8	10kA	1,955
	LCU8015-030	10.5	12.4	15	6.0	7.0	8	10kA	1,995
	LCU8016-036	12.6	14.5	17	7.2	8.0	9	10kA	2,394
LCU8017-042	14.7	16.6	19	8.4	10.0	11	10kA	2,793	
Double Wide Models	LCU8022-015	8.4	10.3	13	4.8	6.0	7	10kA	1,516
	LCU8022-020	8.4	10.3	13	4.8	6.0	7	10kA	1,540
	LCU8022-023	8.4	10.3	13	4.8	6.0	7	10kA	1,564
	LCU8023-031	12.6	14.5	17	7.2	8.0	9	10kA	2,310
	LCU8023-036	12.6	14.5	17	7.2	8.0	9	10kA	2,346
	LCU8024-041	16.8	19.7	22	9.6	11.0	12	10kA	3,080
	LCU8024-048	16.8	19.7	22	9.6	11.0	12	10kA	3,128
	LCU8025-053	21.0	23.9	26	12.0	14.0	15	10kA	3,940
	LCU8025-059	21.0	23.9	26	12.0	14.0	15	10kA	4,030
	LCU8026-069	25.2	28.1	31	14.4	16.0	17	10kA	4,824
LCU8027-082	29.4	32.3	35	16.8	18.0	19	10kA	5,642	

800MM

LCV8 Performance Data

925 Variable Speed EC, 1.75 HP, 800mm Fan Diameter								
	Model	Fan Arrangement	Total Heat of Rejection (MBH/1° F TD)			Air Flow (CFM)	Sound Pressure (dBA @ 3m)	Maximum Number of Circuits
			R-404A/R-507	R-410A	R-134a			
Single Wide Models	LCV8011-007	1X1	7.4	7.7	6.7	12,210	58.5	14
	LCV8011-009	1X1	9.1	9.4	8.4	11,720	58.5	18
	LCV8012-012	1X2	11.2	11.6	10.0	25,190	60.5	20
	LCV8012-015	1X2	15.0	15.4	13.6	23,999	60.5	28
	LCV8012-018	1X2	17.8	18.3	16.3	22,947	60.5	34
	LCV8013-023	1X3	23.2	24.0	20.2	35,999	63.3	28
	LCV8013-027	1X3	26.9	27.7	23.8	34,370	63.3	34
	LCV8014-030	1X4	30.4	31.4	26.5	47,998	64.5	38
	LCV8014-036	1X4	36.1	37.4	31.8	45,827	64.5	42
	LCV8015-041	1X5	40.7	42.1	36.0	56,021	65.5	28
	LCV8015-047	1X5	46.5	47.7	41.7	52,782	65.5	36
	LCV8016-056	1X6	55.6	57.1	49.6	63,338	66.3	44
	LCV8017-064	1X7	64.5	66.4	57.3	73,895	67.0	52
Double Wide Models	LCV8022-022	2X2	21.8	22.5	19.5	49,723	64.5	20
	LCV8022-029	2X2	29.3	30.1	26.6	47,169	64.5	28
	LCV8022-035	2X2	35.0	36.0	31.9	44,885	64.5	32
	LCV8023-045	2X3	45.2	46.9	39.1	70,948	66.3	52
	LCV8023-053	2X3	52.6	54.3	46.3	67,531	66.3	68
	LCV8024-060	2X4	60.3	62.5	52.2	94,660	67.5	76
	LCV8024-071	2X4	70.5	72.9	62.0	90,041	67.5	96
	LCV8025-080	2X5	79.9	82.6	69.3	109,893	68.5	64
	LCV8025-092	2X5	91.7	94.4	80.2	103,112	68.5	90
	LCV8026-108	2X6	107.8	111.9	93.2	123,735	69.3	100
	LCV8027-125	2X7	125.2	130.4	108.4	144,357	70.0	140

For 8 FPI Models, multiply MBH by 0.905, CFM by 1.024, and watts by 0.981.
 For 12 FPI Models, multiply MBH by 1.070, CFM by 0.975, and watts by 1.020.

800MM



LCV8 Electrical Data

925 RPM Variable Speed EC, 1.75 HP, 800mm Fan Diameter									
	Model	208-230/3/60			460/3/60			SCCR	Total Watts
		FLA	MCA	MOPD	FLA	MCA	MOPD		
Single Wide Models	LCV8011-007	5.7	8.0	14	2.9	4.0	7	10kA	1,395
	LCV8011-009	5.7	8.0	14	2.9	4.0	7	10kA	1,447
	LCV8012-012	11.4	13.7	20	5.7	7.0	10	10kA	2,708
	LCV8012-015	11.4	13.7	20	5.7	7.0	10	10kA	2,834
	LCV8012-018	11.4	13.7	20	5.7	7.0	10	10kA	2,946
	LCV8013-023	17.1	19.4	26	8.6	10.0	13	10kA	4,251
	LCV8013-027	17.1	19.4	26	8.6	10.0	13	10kA	4,422
	LCV8014-030	22.8	25.1	32	11.4	13.0	16	10kA	5,668
	LCV8014-036	22.8	25.1	32	11.4	13.0	16	10kA	5,896
	LCV8015-041	28.5	30.8	37	14.3	16.0	19	10kA	7,500
	LCV8015-047	28.5	30.8	37	14.3	16.0	19	10kA	7,840
	LCV8016-056	34.2	36.5	43	17.1	19.0	22	10kA	9,408
LCV8017-064	39.9	36.5	49	20.0	22.0	25	10kA	10,976	
Double Wide Models	LCV8022-022	22.8	25.1	32	11.4	13.0	16	10kA	5,484
	LCV8022-029	22.8	25.1	32	11.4	13.0	16	10kA	5,756
	LCV8022-035	22.8	25.1	32	11.4	13.0	16	10kA	5,996
	LCV8023-045	34.2	36.5	43	17.1	19.0	22	10kA	8,616
	LCV8023-053	34.2	36.5	43	17.1	19.0	22	10kA	8,970
	LCV8024-060	45.6	48.9	55	22.8	25.0	28	10kA	11,488
	LCV8024-071	45.6	48.9	55	22.8	25.0	28	10kA	11,960
	LCV8025-080	57.0	60.3	67	28.5	31.0	34	10kA	15,240
	LCV8025-092	57.0	60.3	67	28.5	31.0	34	10kA	15,920
	LCV8026-108	68.4	71.7	78	34.2	36.0	39	10kA	19,104
LCV8027-125	79.8	83.1	90	39.9	42.0	45	10kA	22,288	

800MM

LC*8 Dimensional Data

Round Tube Models										
	Models			Overall Length (In)	Mounting Dimensions (In.)			Connections (In.) *		Approx. Net Weight (Lbs.)
	LCS8*	LCU8*	LCV8*		A	B	C	Inlet	Outlet	
Single Wide Models	11-007	11-005	11-007	80.9	48.1	---	---	1 3/8	1 1/8	529
	11-009	11-006	11-009	80.9	48.1	---	---	1 3/8	1 1/8	551
	12-011	12-008	12-012	138.9	106.2	---	---	1 3/8	1 1/8	710
	12-015	12-010	12-015	138.9	106.2	---	---	1 5/8	1 3/8	829
	12-018	12-012	12-018	138.9	106.2	---	---	1 5/8	1 3/8	869
	13-022	13-016	13-023	196.9	111.1	53.1	---	2 1/8	1 5/8	1186
	13-026	13-018	13-027	196.9	111.1	53.1	---	2 1/8	1 5/8	1246
	14-030	14-021	14-030	254.9	111.1	111.1	---	2 1/8	1 5/8	1497
	14-035	14-023	14-036	254.9	111.1	111.1	---	2 5/8	2 1/8	1574
	15-040	15-027	15-041	312.9	111.1	169.1	---	2 5/8	2 1/8	1658
	15-046	15-030	15-047	312.9	111.1	169.1	---	2 5/8	2 1/8	1746
	16-054	16-036	16-056	370.9	111.1	116.0	111.1	2 5/8	2 5/8	2068
17-062	17-042	17-064	428.9	111.1	116.0	169.1	(2) 2 5/8	(2) 2 5/8	2368	
Double Wide Models	22-022	22-015	22-022	138.9	106.2	---	---	(2) 1 3/8	(2) 1 1/8	1301
	22-029	22-020	22-029	138.9	106.2	---	---	(2) 1 5/8	(2) 1 3/8	1537
	22-035	22-023	22-035	138.9	106.2	---	---	(2) 1 5/8	(2) 1 3/8	1614
	23-044	23-031	23-045	196.9	111.1	53.1	---	(2) 2 1/8	(2) 1 5/8	2086
	23-052	23-036	23-053	196.9	111.1	53.1	---	(2) 2 1/8	(2) 1 5/8	2196
	24-060	24-041	24-060	254.9	111.1	111.1	---	(2) 2 1/8	(2) 1 5/8	2845
	24-070	24-048	24-071	254.9	111.1	111.1	---	(2) 2 5/8	(2) 2 1/8	2999
	25-081	25-053	25-080	312.9	111.1	169.1	---	(2) 2 5/8	(2) 2 1/8	3603
	25-091	25-059	25-092	312.9	111.1	169.1	---	(2) 2 5/8	(2) 2 1/8	3801
	26-107	26-069	26-108	370.9	111.1	116.0	111.1	(2) 2 5/8	(2) 2 1/8	5040
27-123	27-082	27-125	428.9	111.1	116.0	169.1	(4) 2 5/8	(4) 2 1/8	5836	

*Connections for R-410A applications must not exceed 1 5/8". Specify "R-410A" when ordering for factory consultation. Single wide models use single inlet and outlet headers. Double wide models use 2 inlet and 2 outlet headers with the coil split 50% X 50%.

LC*8 Dimensional Data With Round Tube Coils

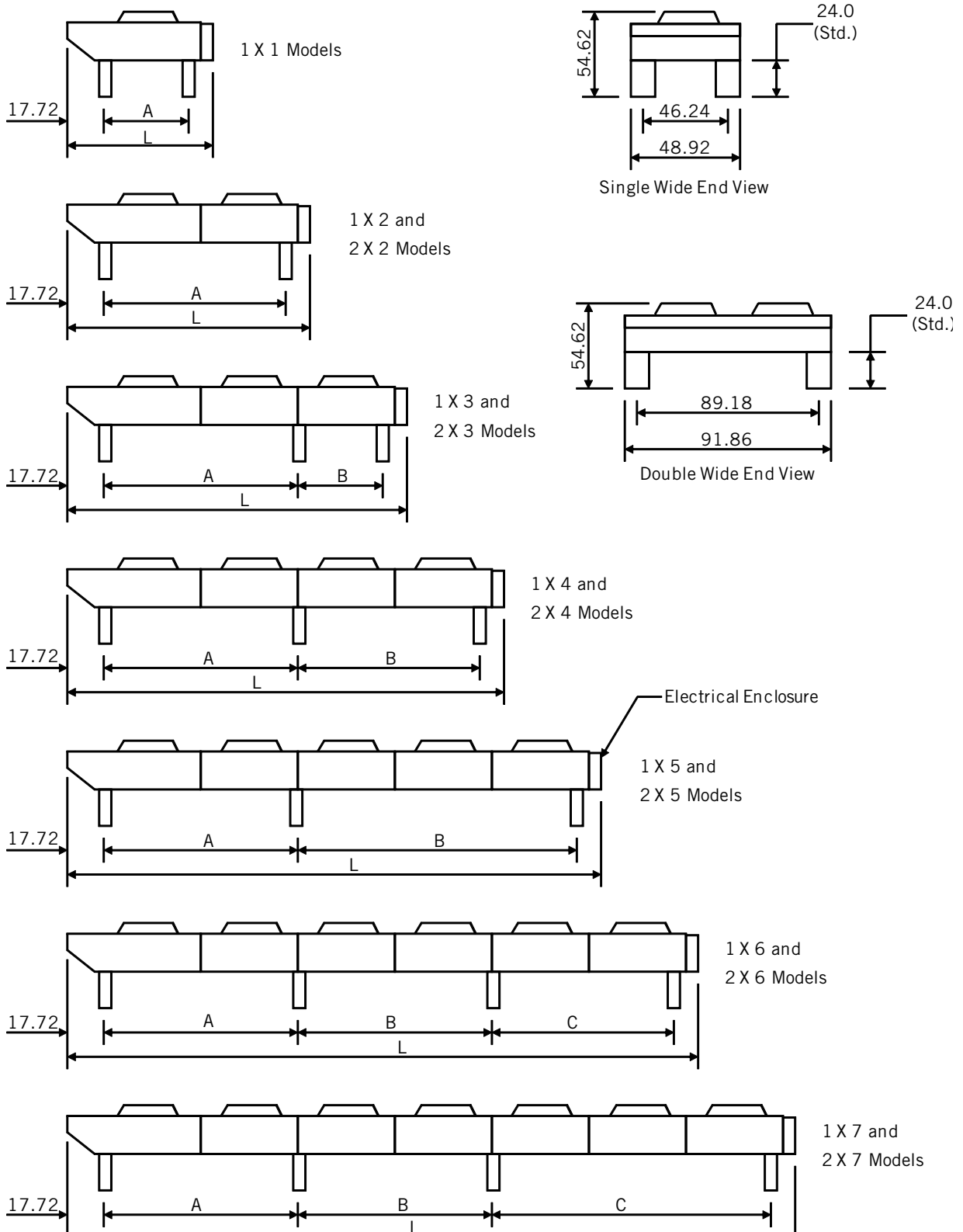

800MM

LC*8 Refrigerant Charge

Round Tube Models									
Models			Summer Refrigerant Charge (Lbs. R-404A)	Additional Refrigerant Charge Required for Flooded Condenser Operation Lbs. R-404A @ 20°F TD)					
				Minimum Ambient Temperature (°F)					
LCS8*	LCU8*	LCV8*		+60	+40	+20	0	-20	
Single Wide Models	11-007	11-005	11-007	10	18	19	19	20	20
	11-009	11-006	11-009	13	24	25	25	26	26
	12-011	12-008	12-012	12	21	22	22	23	23
	12-015	12-010	12-015	18	31	33	33	35	35
	12-018	12-012	12-018	23	42	44	44	47	47
	13-022	13-016	13-023	32	72	75	77	80	82
	13-026	13-018	13-027	43	96	101	103	107	109
	14-030	14-021	14-030	43	95	99	102	106	108
	14-035	14-023	14-036	56	127	133	136	142	145
	15-040	15-027	15-041	94	219	228	238	244	252
	15-046	15-030	15-047	127	293	304	318	325	336
	16-054	16-036	16-056	153	350	363	380	389	402
17-062	17-042	17-064	178	407	422	443	453	468	
Double Wide Models	22-022	22-015	22-022	22	39	41	41	44	44
	22-029	22-020	22-029	33	59	62	62	65	66
	22-035	22-023	22-035	44	78	83	82	88	88
	23-044	23-031	23-045	60	136	143	146	152	155
	23-052	23-036	23-053	81	182	190	194	202	207
	24-060	24-041	24-060	81	180	188	192	200	204
	24-070	24-048	24-071	108	240	251	256	267	273
	25-081	25-053	25-080	181	414	430	450	460	476
	25-091	25-059	25-092	248	552	573	600	614	634
	26-107	26-069	26-108	293	661	685	718	734	759
27-123	27-082	27-125	349	767	796	834	853	881	

Flooded Charge Adjustment Factors for Alternate Conditions

Design TD (°F)	Minimum Ambient Temperature (°F)				
	60	40	20	0	-20
10	2.46	1.4	1.25	1.16	1.13
15	1.74	1.19	1.13	1.07	1.05
20	1	1	1	1	1
25	0.38	0.8	0.88	0.91	0.93
30	----	0.59	0.76	0.84	0.88

For R-507, multiply values by 1.035
 For R-410A, multiply values by 1.026
 For R-134a, multiply values by 1.088



Control Panels

The standard control panel for LC*8 air-cooled condensers include a non-fused disconnect switch with door interlock and a terminal board for the motor leads. A wide variety of optional controls are also available for circuit protection, fan cycling, splitting, variable speed, and micro-processor controller interfaces.

Circuit Protection

Available options include primary fusing and motor branch circuit fusing. Individual motor fusing is supplied with individual contactor options and all LCU8 models. Paired motor fusing is supplied with paired contactor options.

Motor Contactors

Motor contactors are required as part of the fan motor protection system for all single speed motors. Variable speed EC motors do not require contactors and they are not recommended for use with these motors. For these reasons, motor contactors are supplied as “optional” accessories and are offered as one contactor per each fan motor (“Individual Contactors”) or one contactor per pair of adjacent fan motors (“Paired Contactors”).

Fan Cycling

Optional electronic controls are available to cycle single speed fans on ambient temperature or condensing pressure inputs with the following features:

- Fans closest to the headers run continuously.
- All single speed fan motors are cycled with contactors (ordered separately).
- Single wide models cycle fans individually (one contactor per fan motor).
- Double wide models cycle fans in adjacent pairs (one contactor per pair of fan motors).
- Standard control circuits are 230 volts. 115 volt is available upon request.
- Control branch circuit fusing is included with all fan cycling options.
- A control circuit transformer is supplied, as needed, with all fan cycling options.
- All fan cycling options include an ambient temperature sensor or pressure transducer.
- A controller is provided with all fan cycling options. Luvata uses only electronic fan cycle controllers to economically provide the most accurate and reliable system.

Ambient Fan Cycling

Ambient fan cycling is recommended for multi-circuited condensers or where there is little variation in condenser load. It is limited in its ability to control head pressure at colder temperatures (see Table 1) and should be combined with another means of head pressure control, such as condenser flooding and/or variable speed, in these situations. See Table 3 for recommended controller settings.

Table 1 - Minimum Ambient Temperature for Fan Cycling

Number of Fans Long	Design TD °F				
	10	15	20	25	30
2	70	60	55	45	35
3	65	55	40	30	15
4	60	45	30	15	0
5	55	35	20	10	0
6	50	30	10	0	0
7	50	30	10	0	0

800MM

Pressure Fan Cycling

Since these controls sense actual condenser pressure, they will cycle fans at any ambient temperature. This makes them ideal for colder climates and systems with widely varying condenser loads. They may also be combined with additional forms of head pressure control, such as condenser flooding and/or variable speed, to further enhance performance. See Table 2 for recommended controller settings.

Table 2 - Fan Cycle Control Temperature & Pressure Settings

	Header End													
	M1	M3	M5	M7	M9	M11	M13	M2	M4	M6	M8	M10	M12	M14
Stage	---		1		2		3		4		5		6	
Contactors	C1		C2		C3		C4		C5		C6		C7	
# Fans Long	Always On		On	Off	On	Off	On	Off	On	Off	On	Off	On	Off
Temperature Control (°F)														
2			70	65										
3			70	65	80	75								
4			70	65	75	70	80	75						
5			70	65	75	70	80	75	85	80				
6			70	65	75	70	80	75	85	80	90	85		
7			70	65	75	70	80	75	85	80	90	85	95	90
R-404A Pressure Control (PSIG)														
2			220	185										
3			220	185	245	210								
4			220	185	235	200	250	215						
5			220	185	235	200	250	215	260	225				
6			220	185	235	200	245	210	255	220	265	230		
7			220	185	235	200	245	210	255	220	265	230	270	235
R-410A Pressure Control (PSIG)														
2			300	255										
3			300	255	330	285								
4			300	255	320	275	335	290						
5			300	255	320	275	335	290	350	305				
6			300	255	320	275	335	290	350	305	360	315		
7			300	255	320	275	335	290	350	305	360	315	365	320
R-134a Pressure Control (PSIG)														
2			115	90										
3			115	90	130	105								
4			115	90	125	100	135	110						
5			115	90	125	100	135	110	140	115				
6			115	90	125	100	130	105	135	110	140	115		
7			115	90	125	100	130	105	135	110	140	115	145	120

Note: Motor contactor to be wired to "NO" contact of fan cycle control

Variable Speed

With this option, the single speed header fan(s) are replaced with ultra-high efficiency variable speed EC fan motors (one fan motor on single wide units, two on double wide units). Condenser head pressure is controlled by varying the air flow of the header fan(s) via changing speed of the variable speed fan motor(s). All variable speed EC motors are controlled in response to a condensing pressure input. The remainder of the single speed fan motors are cycled on and off using pressure or ambient fan cycling. This design allows the variable speed fan(s) to maintain a consistent head pressure by ramping up and down in response to fluctuating loads, varying ambient temperatures and fan cycling. The control package includes factory installation and wiring of variable speed fan motor(s), controller (variable speed and fan cycling), pressure transducer and temperature sensor, as required, for proper operation.

Splitting Controls

Additional head pressure control can be achieved by isolating a portion of the condenser circuit and removing that portion from the refrigeration circuit. In addition to providing a means of head pressure control, condenser splitting will reduce the amount of refrigerant required to operate the condenser with flooded head pressure control. Condenser splitting should be set up as a seasonal adjustment controlled by ambient temperature. A pressure switch is also provided as backup protection against unexpected high load conditions. On single wide condensers, this option includes a controller, an ambient temperature sensor, a pressure transducer, and a splitting relay. The splitting relay provides a set of control contacts for field wiring to the splitting valves (supplied by others) installed remotely from the condenser. For double wide condensers, additional controls are provided to cycle off all the fans on the isolated side of the condenser. Pressure fan cycling (not included) is recommended for use with splitting controls.

Micro-Processor Control Interfaces

This option includes interface boards from many micro-processor control manufacturers installed in the control panel and wired to customer specifications. This often requires the addition of individual motor fusing, individual motor contactors, and splitting relays. Micro-processor controls replace the need for fan cycling control options.

Typical Wiring Diagram with Individual Contactors

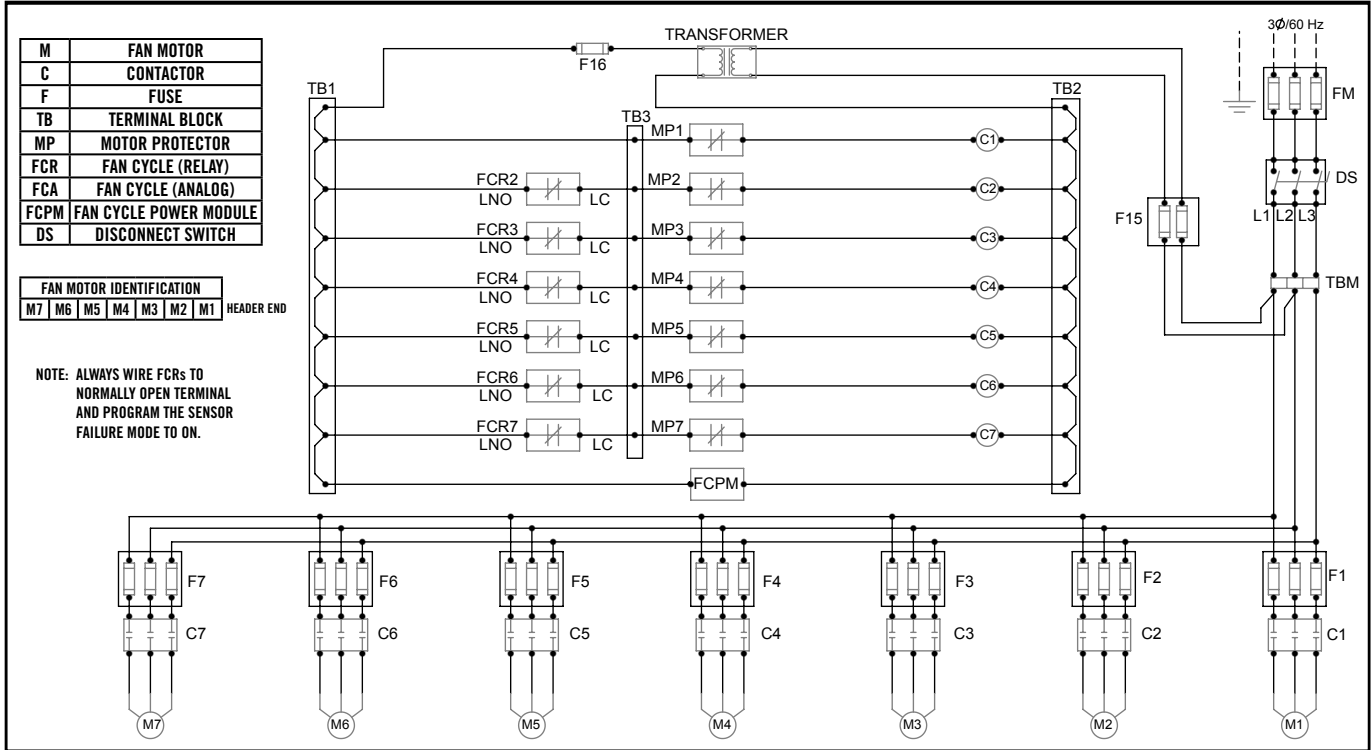

Typical Wiring Diagram with Paired Motor Contactors

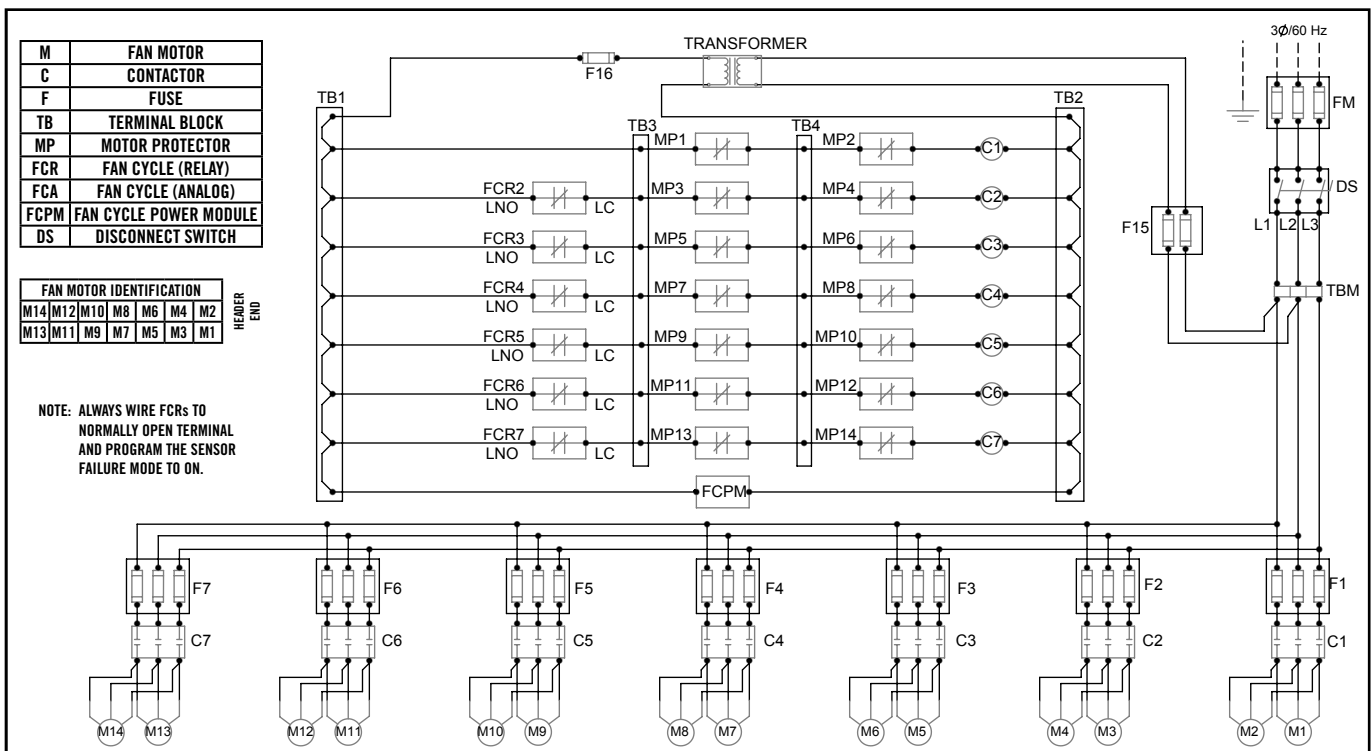

Typical Wiring Diagram with Variable Speed Header Fans

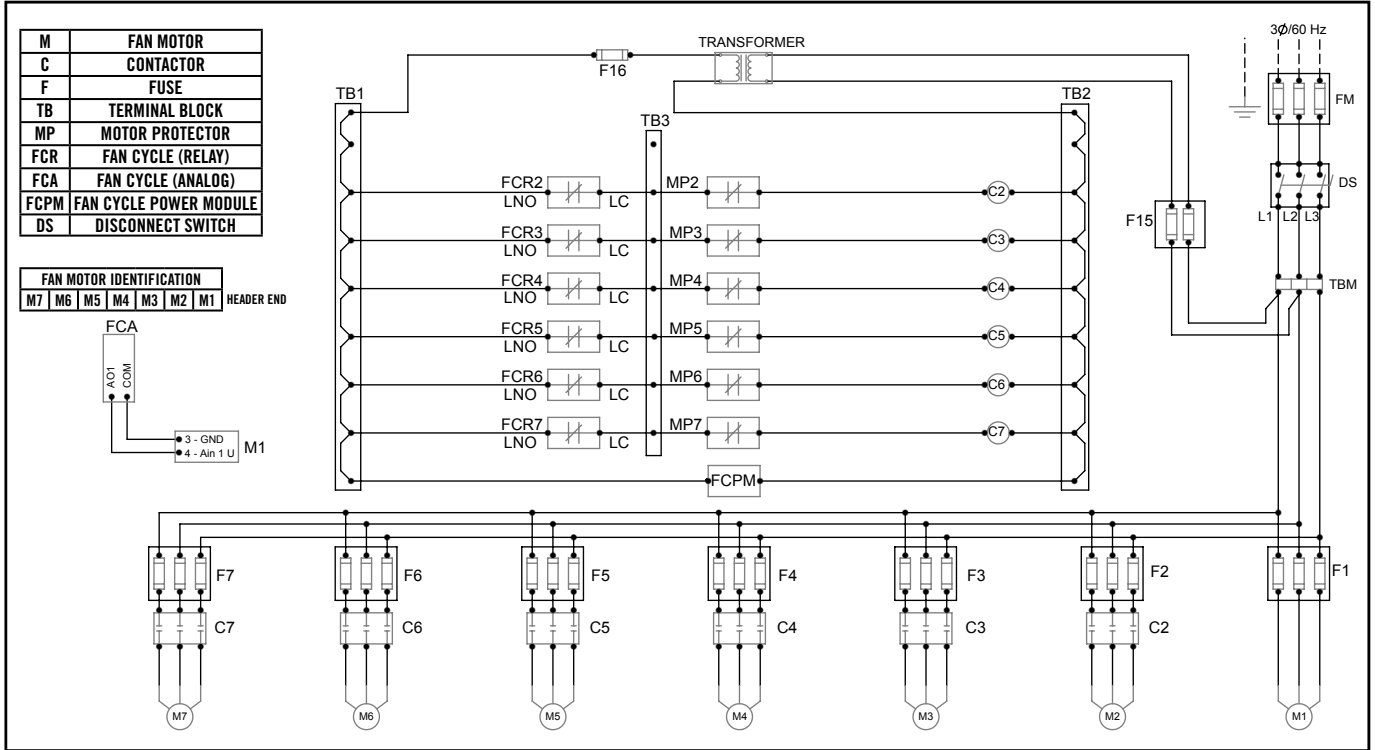

Typical Wiring Diagram with VSEC Fan Motors

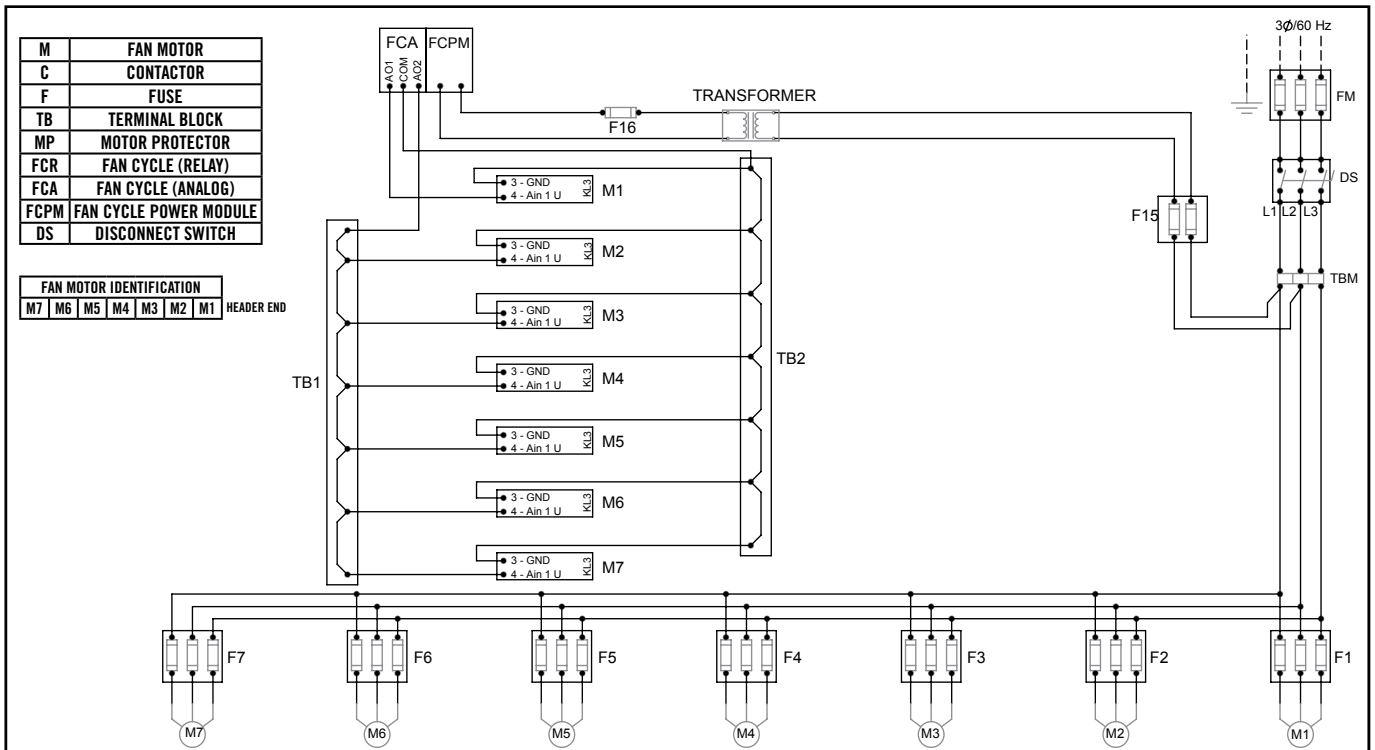

Air-Cooled Condenser Selection

Required condenser Total Heat of Rejection (THR) is equal to the sum of the evaporator load(s) and the heat of compression created by the compressor(s). Heat of compression will vary based on the type of compressor and the compressor operating conditions.

THR Calculation Method

Open Type Compressors (air cooled) :

$$\text{THR} = \text{Compressor Capacity (MBH)} + 2.545 \times \text{BHP}$$

Refrigerant Cooled Compressors:

$$\text{THR} = \text{Compressor Capacity (MBH)} + 3.413 \times \text{kW}$$

THR Estimation Method

Open Type Compressors (air cooled):

$$\text{THR} = \text{Compressor Capacity (MBH)} \times \text{Table 4 Factor}$$

Refrigerant Cooled Compressors:

$$\text{THR} = \text{Compressor Capacity (MBH)} \times \text{Table 3 Factor}$$

Table 3: Heat of Compression Factors for Suction Cooled Compressors

Evaporator Temp (°F)	Condensing Temperature (°F)					
	90	100	110	120	130	140
-40	1.66	1.73	1.80	2.00	---	---
-30	1.57	1.62	1.68	1.80	---	---
-20	1.49	1.53	1.58	1.65	---	---
-10	1.42	1.46	1.50	1.57	1.64	---
0	1.36	1.40	1.44	1.50	1.56	1.62
10	1.31	1.34	1.38	1.43	1.49	1.55
20	1.26	1.29	1.33	1.37	1.43	1.49
30	1.22	1.25	1.28	1.32	1.37	1.42
40	1.18	1.21	1.24	1.27	1.31	1.35
50	1.14	1.17	1.20	1.23	1.26	1.29

Table 4: Heat of Compression Factors for Open Type Compressors

Evaporator Temp (°F)	Condensing Temperature (°F)					
	90	100	110	120	130	140
-30	1.37	1.42	1.47	---	---	---
-20	1.33	1.37	1.42	1.47	---	---
-10	1.28	1.32	1.37	1.42	1.47	---
0	1.24	1.28	1.32	1.37	1.41	1.47
10	1.21	1.24	1.28	1.32	1.36	1.42
20	1.17	1.20	1.24	1.28	1.32	1.37
30	1.14	1.17	1.20	1.24	1.27	1.32
40	1.12	1.15	1.17	1.20	1.23	1.28
50	1.09	1.12	1.14	1.17	1.20	1.24

800MM



Lower air density at higher elevations reduces the performance of air-cooled condensers and is accounted for by increasing the required THR using the factors in Table 5.

Table 5: Altitude Correction Factors for Air-Cooled Condensers

Feet	Factor
1,000	1.02
2,000	1.05
3,000	1.07
4,000	1.10
5,000	1.12
6,000	1.15
7,000	1.17
8,000	1.24

Selection Example

Compressor Capacity 380 MBH
 Evaporating Temp. +25°F
 Ambient Temp. 95°F
 Design TD 15°F
 Altitude 2000 Feet
 Refrigerant R-404A
 Compressor Type Ref. Cooled

From Table 3, the heat of compression factor for +25°F evaporating and 110°F condensing (= ambient temp + TD) is 1.31. From Table 5, the altitude correction factor is 1.05.

Required THR = 380 X 1.31 X 1.05 = 522.7 MBH
 or, 522.7/15 = 34.85 MBH/1°F TD

Possible solutions are

Model	rpm	Fans	Rated MBH/1°F TD	Actual TD*
LCS8014-035	1100	1 X 4	35.1 MBH/1°F TD	14.9°F.
LCS8022-035	1100	2 X 2	34.6 MBH/1°F TD	15.1°F.
LCU8016-036	500	1 X 6	35.9 MBH/1°F TD	14.6°F.
LCU8023-036	500	2 X 3	35.8 MBH/1°F TD	14.6°F.
LCV8014-036	925 VSEC	1 X 4	36.1 MBH/1°F TD	14.5°F.
LCV8022-035	925 VSEC	2 X 2	35.0 MBH/1°F TD	14.9°F.

* Actual TD = Required THR/Rated THR X Design TD

All of these models will work properly for the application. Final selection should be based upon the desired features and capabilities of the various model designs.

Multi-Circuit Condenser Selection

Air-cooled condenser coils may be divided into multiple independent circuits: each sized for a specific THR, TD, and refrigerant. Each circuit is supplied with its own inlet and outlet connections and are identified from left to right when facing the header end of the unit.

The THR calculation for each circuit uses the same method outlined in the preceding section except that Refrigerant Capacity Factors (Table 8) are applied when using refrigerants other than R-404A. The individual circuit THR's are then added together to determine the overall unit THR required and selecting a specific air-cooled condenser model. The final step is to determine how to divide the total number of available feeds into individual circuits.

Guidelines for multi-circuiting:

- Avoid locating high TD circuits next to low TD circuits.
- Add excess feeds to low TD circuits located near high TD circuits.
- The refrigerant charge for each circuit may be calculated as actual feeds ÷ total feeds X refrigerant charge for unit.

Table 6-Method of Selecting Model for Multi-Circuiting

Circuit #	Refrig	Design Ambient (°F)	Evap Temp (°F)	Cond Temp (°F)	Evap Load (MBH)	x	Heat of Compr. Factor	x	Altitude Factor	÷	Refgnt Factor	÷	Design TD (°F)	=	Required THR (MBH/1°F)
1	R-404A	95	-20	105	70	x	1.52	x	1.05	÷	1.00	÷	10	=	11.17
2	R-134a	95	+25	110	125	x	1.31	x	1.05	÷	0.89	÷	15	=	12.88
3	R-410A	95	+45	120	200	x	1.26	x	1.05	÷	1.03	÷	25	=	10.28
													Total	=	34.33

Select Model LCS8022-035 with 32 available feeds. R-404A = 34.6 MBH/1°F
 R-134a = 31.6 MBH/1°F
 R-410A = 35.5 MBH/1°F

Table 7-Method of Specifying the Number of Feeds per Circuit

Circuit #	Required THR (MBH/1°F)	÷	Available THR (MBH/1°F)	x	Available #Feeds	=	Required # Feeds	Actual # Feeds	% Total # Feeds	x	Available THR (MBH/1°F)	=	Actual THR (MBH/1°F)	Actual TD (°F)	
1	11.17	÷	34.6	x	32	=	10.3	10	31%	x	34.6	=	10.81	10.3	
2	12.88	÷	31.6	x	32	=	13.0	13	41%	x	31.6	=	12.84	15.0	
3	10.28	÷	35.5	x	32	=	9.3	9	28%	x	35.5	=	9.98	25.8	
Total	34.33							32	100%			33.63			

Table 8-Refrigerant Capacity Factors

Refrigerant Capacity Factors	
Refrigerant	Factor
R-404A	1.00
R-410A	1.03
R-134a	0.89

800MM



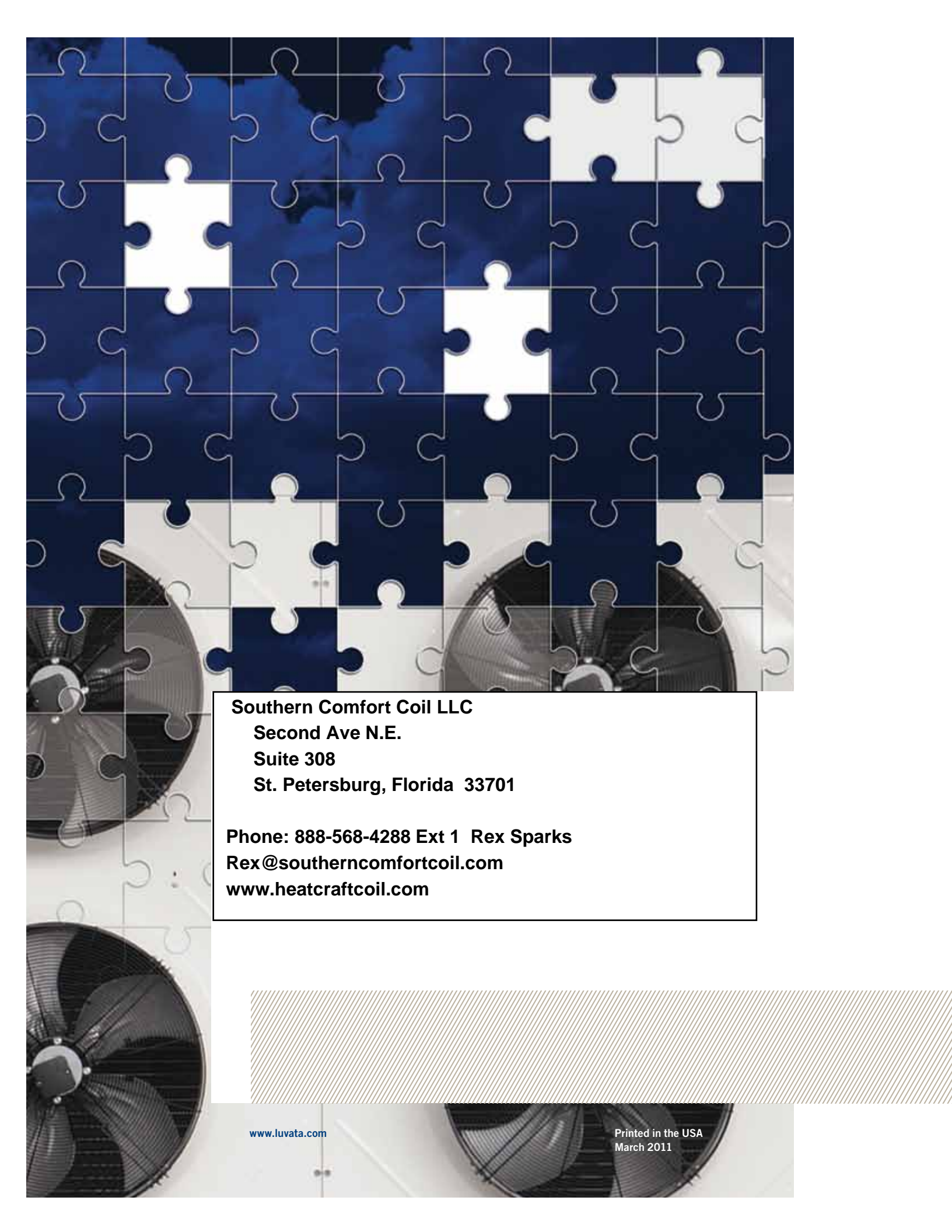

**Southern Comfort Coil LLC
Second Ave N.E.
Suite 308
St. Petersburg, Florida 33701**

**Phone: 888-568-4288 Ext 1 Rex Sparks
Rex@southerncomfortcoil.com
www.heatcraftcoil.com**